



Reusable Silicone Breathing Masks

111 Series

REF

7600606

7600607

7600608

General Description

Reusable Silicone Breathing Masks are noninvasive accessories used to deliver airflow from positive airway pressure (PAP), anesthesia and ventilation devices to the patient. Masks are for single-patient use at home or for multi-patient use in a hospital/healthcare setting. In order to ensure the correct use of masks at home, in the hospital/health institution environment, cooperation should be made with the doctor and healthcare personnel.

This guide covers the following variants, which are mentioned at the below of the guide:

- 7600607 non-vented full face mask (Standard (blue) elbow to indicate that the mask does not include its own exhalation port or an AAV)
- 7600606 non-vented full face mask with AAV (clear elbow indicate that the mask does not incorporate its own exhalation port.)
- 7600608 vented full face mask (Orange elbow to indicate that mask include an exhalation port is built into the mask and an AAV).

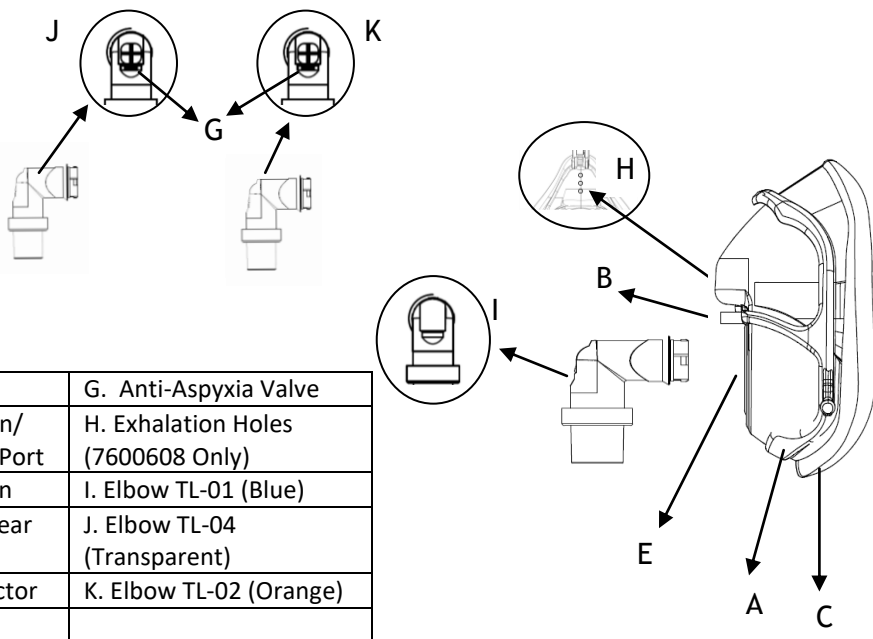

Components of Mask



Intended Use

The Full-Face Mask channels airflow from ventilator/Positive Air Pressure (PAP) devices non-invasively to the patients who suffer from obstructive sleep apnea (OSA) or respiratory insufficiency and respiratory failure.







CAUTION: It is important to use the correct mask that matches the respiratory aid system. Please check the elbow before using it. See the below table for details.









REF	Elbow	AAV Valve	Color	
7600607	 (TL-41)	No	Blue	requires active exhalation valve at/on Ventilator devices
7600606	 (TL-44)	Yes	Transparent	requires active exhalation valve at/on PAP devices
7600608	 (TL-42)	Yes	Orange	No separate exhalation valve required

Notes:

This mask is not made with natural rubber latex or DEHP.

SYMBOLS OF THE COMPONENTS

<i>Image of Symbol</i>	<i>Meaning of Symbol</i>	<i>Image of Symbol</i>	<i>Meaning of Symbol</i>
	Manufacturer		Non-sterile
	Read instructions for use		European Conformity Mark
	Protect from sunlight		Batch Code

	Keep dry and cool area	REF	Catalog Number
	Store between 0 °C (± 5) and +50 (± 5).		Expiration date
	Latex Free	UDI	Unique Device Identifier
MD	It is a medical device	AAV	Anti-Asphyxia Valve
	Do not use if the packaging is damaged.		Made In Türkiye
	Does not contain DEHP.		Humidity limitation between 40% and 70%

Indications

It is indicated to be used for the conditions which required CPAP, Bi PAP and Auto PAP therapy like obstructive sleep apnea syndrome, chronic obstructive pulmonary disease with exacerbation, acute congestive heart failure with pulmonary edema, acute lung injury, neuromuscular disorders, pneumonia, ventilator weaning.

Contraindications

This mask may not be suitable for use on patients with the following conditions:

- the necessity for immediate intubation,
- glaucoma, recent eye surgery or dry eyes
- hiatal hernia, excessive reflux, dysfunctional cough reflex, impaired cardiac sphincter function, cardiorespiratory instability
- Skin allergies,
- flush of the facial skin,
- intake of medication which may induce vomiting,
- Unconsciousness.
- Facial or nasopharyngeal deformity
- on patients unable to remove the mask by themselves

Also observe the contraindications in the Instructions for use of your therapy device.

⚠ Warnings and precautions

Discontinue using this mask if the patient has ANY adverse reaction to the use of the mask.

Use of this mask while the system is not on and operating may cause rebreathing of exhaled air.

Vented variant only: Do not block or try to seal the exhalation hole.

Only use non-vented full-face masks in combination with therapy devices equipped with an active exhalation valve.

Only use the mask within the quoted therapy pressure range.

At low CPAP or EPAP pressures the flow through the exhalation port may be inadequate to clear all exhaled gas from the tubing. Some rebreathing may occur.

This mask is not suitable for providing life support ventilation.

This mask should not be used on patients who are uncooperative, obtunded, unresponsive, or unable to remove the mask.

Check before every use that the openings of the anti-asphyxia valve (AAV) are clear. (On 7600606 and 7600608) If the therapy device fails, the anti-asphyxia valve opens so that the patient can breathe ambient air.

Follow all precautions when using supplemental oxygen.

Oxygen flow must be turned off when the flow generator is not operating, so that unused oxygen does not accumulate within the flow generator enclosure and create a risk of fire.

Images shown here are indicative only. If there is inconsistency between the image and actual product, the actual product shall govern.

Inspect all parts of your Nasal Masks for damage; replace that are visibly deteriorated due to cracking, crazing, tears, etc.

Do not overtighten the headgear straps. Watch for signs of overtightening, such as excessive redness, sores, or bulging skin around the edges of the mask. Loosen the headgear straps to alleviate problems.

This mask is designed for use with CPAP or bi-level systems recommended by your health care professional or respiratory therapist. Do not wear this mask unless the CPAP or bi-level system is turned on and operating properly.

Longtime use of masks can cause pressure ulcers

Intended User

The device is to be used by healthcare professionals (doctors, nurses, technicians) or by laypersons who have been prescribed non-invasive ventilation therapy and who are capable of understanding and following the instructions for use.

Intended Patient Population

The mask is to be used by adult patients (> 30 kg) requiring non-life-support ventilator assistance.

Intended User

The device is to be used by healthcare professionals (doctors, nurses, technicians) or by laypersons who have been prescribed non-invasive ventilation therapy and who are capable of understanding and following the instructions for use.

Expected Clinical Benefits

The expected clinical benefits and claims of KNGMED REUSABLE SILICONE BREATHING MASKS are as follows:

Reusable Silicone Breathing Masks deliver airflow from positive airway pressure (PAP) and ventilation devices to the patient in an effective and safe way.

Possible Side Effects and Adverse Events

There are no known complications or side effects.

Device Limitations or Incompatibility Risks

The mask shall only be used with compatible CPAP, BiPAP, or Auto-PAP devices as specified by the manufacturer.

It must not be used with life-support ventilators.

Do not use non-original or modified accessories.

Reuse and reprocessing must follow validated cleaning and disinfection procedures.

Application Site In The Body

The device is applied externally to the patient's face to deliver positive airway pressure through the nasal and/or oral region.

ADVERSE CASE

Serious adverse events related to the reusable silicone breathing mask device must be reported to the competent authority of the Member State in which the user and/or patient is resident and to the manufacturer.

Before Use

Read and understand the instructions.

Remove all packaging before using the Masks.

Hand wash mask.

Inspect all parts of your Masks for damage; replace that are visibly deteriorated due to cracking, crazing, tears, etc.

Clean patient's face.

Always keep the vent holes clear and open.

Verify therapy device pressure(s).

Fitting The Mask Tips:

1. Check and make sure that the elbow on the mask is the one that the patient needs. Then, pass the upper straps of the headgear through the installation hole of the mask as shown in the figure and secure it, repeat the process with the lower straps. (Fig.1)
2. Place the mask on the face and extend the headgear to the back of the head (Fig.2)
3. Extend the upper-half straps of the headgear as shown in the above figure until the mask is fixed properly. (Fig.3)
4. Bring the lower-half straps beneath the ear and encircle the face and then place the headgear clips into the fixed hook on the lower-half part of the mask frame.

5. Place the clip in an upright position and place it on the hook. (To remove clips, place it in an upright position and remove it from the hook.)(Fig4)
6. Repeat the process for the lower-half headgear as shown in the above figure until the mask is fixed properly. (Fig5)
7. Open the device for the air supply. Attach the respiratory hose with the connector on the base of the mask. Adjust the position of the mask to confirm a tight seal.

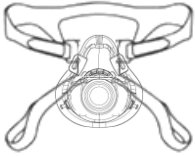

Fig1



Fig2



Fig3

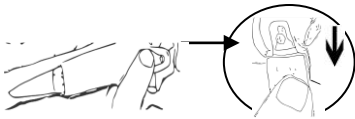

Fig4



Fig5

Comfort Tips :

The most common mistake is overtightening the headgear. The headgear should fit loose and comfortable. If your skin bulges around the mask or if you see red marks on your face, loosen the headgear.

Adjust the bottom headgear straps to reduce leaks at the sides of your mouth.

Removing the Mask

Disconnect the headgear clips and pull over the top of your head

Oxygen / Pressure Port Connector

There are two ports on the base of the mask for taking pressure readings and / or adding additional oxygen.

1. Open the Stopples (F).
 2. Place the Pressure and / or Oxygen Tube firmly over the port (s)(G).
- Note: The two ports are identical; either port may be used for oxygen or pressure measurement. Only remove the Cap (F) from ports that are being used. If you are not using this port, cover the port with the provided cap.

Disinfection

⚠ This process should be used for multiple uses in the hospital.

This Mask can be Autoclave vapor at 121 °C 15 Minutes for 10 times.

1. Enclose those components of the mask that can be disinfected sterilization peel pouch as described in the instructions for the autoclave.
2. Place in the autoclave for the required time. See overleaf for appropriate mask validated times.
3. Remove the mask from the autoclave.
4. Store in clean conditions.
5. After autoclaving and using the product 10 times, dispose of all parts according to your institution's protocol. Follow all local, state, and federal regulations with respect to environmental protection.

Cleaning your mask in the home

⚠ This process should be used for a single patient at home.

Your mask and headgear should only be gently handwashed. Daily/After each use:

- Disassemble the mask components according to the disassembly instructions.
- Thoroughly clean the separated mask components (excluding headgear), by gently rubbing in warm (approximately 86°F/30°C) water using mild soap.
- To optimise the mask seal, facial oils should be removed from the cushion after use.
- Use a soft bristle brush to clean the vent.
- Inspect each component and if required, repeat washing until visually clean.
- Rinse all components well with drinking quality water and allow to air dry out of direct sunlight.
- When all components are dry, reassemble according to the reassembly instructions. Weekly:
 - Handwash the headgear.

⚠ Cautions:

- Do not use bleach, alcohol, cleaning solutions containing bleach or alcohol, or cleaning solutions containing conditioners or moisturizers.
- Do not place the fabric parts into the dryer.
- Any deviation from these instructions may impact the performance of the product.
- Inspect the entire mask for damage or wear (cracking, crazing, tears, damage, etc). Discard and replace any parts as necessary.

Dishwashing Instructions

- In addition to hand washing, the mask may be cleaned in the dishwasher once a week. ⚠ Caution: Use a liquid dish washing detergent only to wash the mask.
- Remove the headgear. Do not wash the headgear in the dishwasher.
- Separate the cushion and the frame and wash in the top shelf of the dishwasher.
- Air dry. Make sure the mask is dry before use.

- **⚠ Warning:** Inspect the mask for damage or wear (cracking, crazing, tears, etc). Discard and replace any parts as necessary.

Troubleshooting

problem	possible cause	solution
Mask wearer uncomfortable	headband strap is too tight	even adjust the headgear, that forehead bracket "fixed" mask, should be secured at the forehead
	wearing tight	Loosen Headgear
mask too noisy		If the cushion is fixed properly installed, the problem still exists, please consult your doctor.
Mask leaks around the face	mask not positioned correctly will cushion	gently pulled away from the face, making it swell again, follow the instructions to put the mask back in place.
	air leakage around the nose	tighten Headgear
	air leakage around the top of the lip	tighten headgear

Technical Specifications :

Therapy pressure range:	4 hPa - 40 hPa	
Hose connection.:	Ref:7600606 - 7600608	Ø 22 mm (male)
	Ref:7600607	Ø 22 mm (female)
Oxygen/Pressure port:	Ø 4 mm	
Temperature range:	Storage: (0° C to 50° C)	
Relative Humidity:	15% to 95%, non-condensing	
Drop in Pressure	at 50 l/min 0,4 hPa	at 100 l/min 1 hPa
Anti-asphyxia valve flow resistance:	Inspiration at 50 l/min 0,9 hPa	Expiratory at 50 l/min 0,6 hPa
Switching pressure for	Open to	Closed to

anti-asphyxia valve :	Atmosphere 0,9 hPa	Atmosphere 1,2 hPa
Sound Levels :	27 dBA	
Deadspace:	S 225 ml	
	M 236 ml	
	L 245 ml	

Pressure Flow Curve

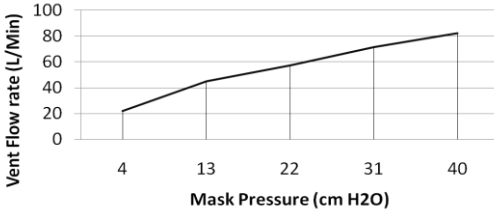

Disposal

The device must be treated as a medical waste and disposed of in accordance with local regulations.

⚠ Warning: The technical specifications of the mask are provided for the healthcare professional to determine if it is compatible with the CPAP or bi-level therapy device. If used outside these specifications, or if used with incompatible devices, the mask may be uncomfortable, the seal of the mask may not be effective, optimum therapy may not be achieved, and leak, or variation in the rate of leak, may affect device function.



Kngmed Medikal Elektronik Sağlık Hizmetleri ve Kimyasal Maddeler İth.İhr.Tic.Ltd.Şti
29 Ekim Mah. 10011 Sk. No:4
Menemen/İzmir/Türkiye